

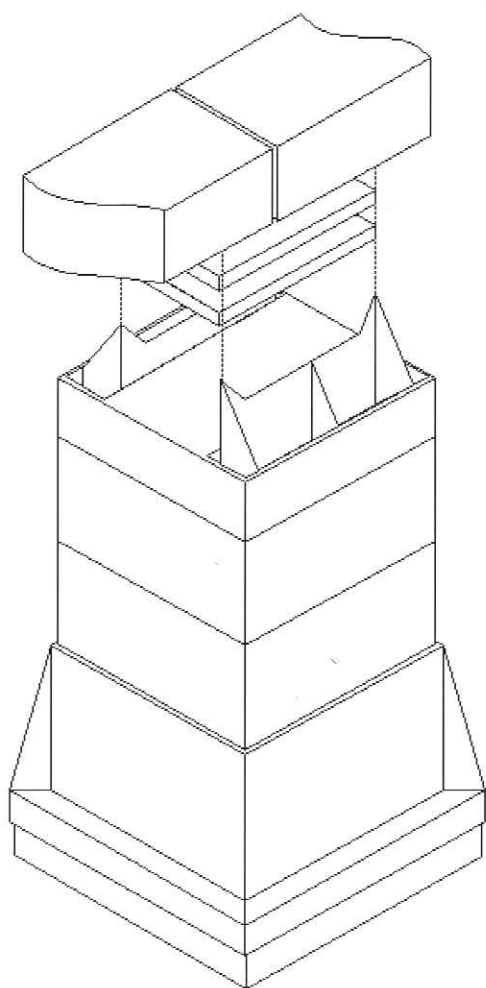
An Introduction to **NEW ERA**

As the name suggests **NEW ERA** provides a new standard in flooring levelling systems through progressive development and a complete understanding of problems inherent with uneven subfloors.

NEW ERA achieves a Practical Cost Effective and Versatile solution in overcoming inconsistencies in variable subfloor levels.

NEW ERA is the ideal means of attaining the correct and required finished floor level.

Plan aheadspecify **NEW ERA**



You have probably walked on our floors.



Multi Component System S10

Practical

Designed for traditional Batten floor construction for Commercial, Domestic and Multisports flooring.

NEW ERA Levelling Elements or "cradles" are resilient foam-backed injection moulded modular flooring supports. Formed from polypropylene **NEW ERA** components are impervious to moisture and are extremely durable.

The 90mm square levelling Elements effectively "cradle" 50mm wide softwood battens, each "cradle" allowing for upto 20mm of packing to be inserted and retained beneath the batten.

Thus levelling the system.

NEW ERA levelling Elements are available in a wide range of heights to cater for most level deviations whilst keeping packing within the 20mm maximum. Pre-cut Packers from 2mm to 18mm are readily available.

NEW ERA is simple and quick to install and easy to specify especially when supplied as a complete system. See the

specifier's page in this brochure or contact your flooring supplier for specific requirements. **NEW ERA** is recognised by major flooring suppliers as being an effective problem solver in over coming uneven subfloors.

Cost effective

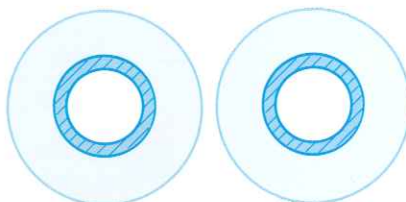
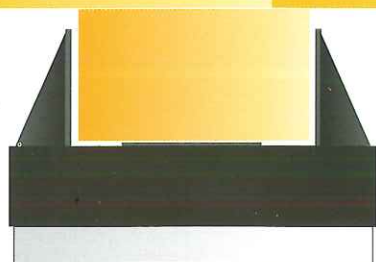
NEW ERA does not require a subfloor produced to tight tolerances. When planning your installation remember **NEW ERA** can eliminate the need for a costly screed or power floated base.

NEW ERA levelling systems are dry installations with no base drying time to consider - few moisture problems and at less cost.

The accepted standard tolerance for a batten floor "base" is defined in BS 8204 Part 1 and is a maximum level deviation of 3mm over 3 LM. Increases to this tolerance can affect both the floor and its warranty.

NEW ERA systems are often used to

Sports halls Gymnasiums Squashcourts **NEW ERA** Dance floors Night clubs Studios



Water and Circulation Pipes

remedy level discrepancies where tolerances within a concrete base or screed have not been met. *Unfortunately an unsuccessful base can sometimes leave insufficient floor depth for a remedial levelling system....*

If possible plan ahead....

our construction heights begin at 74mm.

*...specify **NEW ERA** from Day 1.*

Versatile

NEW ERA levelling systems offer far more than the ability to overcome average or out of tolerance level deviations.

System construction heights range from 74mm to 441mm allowing for a wide range of services, under floor heating and insulation to be installed within the floor void.

NEW ERA can overcome large "step" level deviations and "wells" often found in the subfloors of old building being redeveloped.

The combined benefits of using **NEW ERA** for both standard and non standard applications are evident in the systems compliance with the following British Standards.

- BS6399 part 1 table 8**
- Static Floor Loadings**
- BS2750 part 7 1980**
- Acoustic Insulation**
- BS7044 part 4**
- Multisports use**

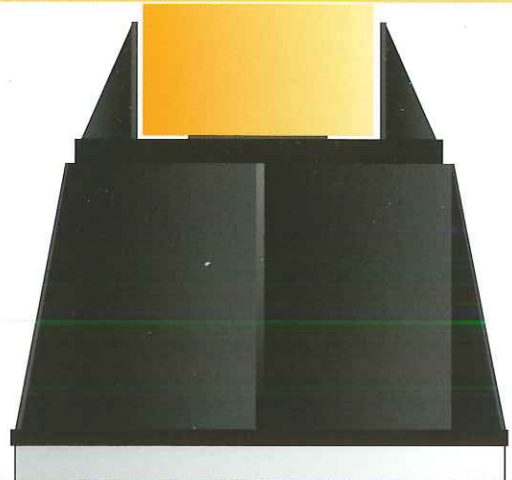
NEW ERA levelling elements are available in three module types:-

Single component "cradles"
construction range 74mm to 150mm

Double component "height extender"
construction range 134mm to 216mm

Multi-component "towers"
construction range 199mm to 441mm

The ability to support and level batten floor systems within this range makes **NEW ERA** probably the most versatile levelling system available.



Double Component System S7

Durable

NEW ERA has a reputation as being a strong, well produced modular system. The first polypropylene units fitted with resilient foam pads were manufactured in the early 90's with the first significant installation being the main sports hall at Cranford Community Centre near Heathrow Middlesex. **NEW ERA** was specified to level and support 500m² of Junkers 22mm Flamey Beech on 36mm softwood battens.

The system levelling elements were a new design. The components used for their fabrication, both then and now, were chosen for their known individual qualities. Polypropylene for its integral strength and the resilient foam pads for their successful association with foam backed battens.

By way of monitoring the life expectancy of the system **NEW ERA** has the Cranford installation periodically checked by V.A. Hutchinson Flooring of Bognor Regis, who carried out the original installation. The system below the shooting circle of the basket ball court is inspected. There has been no deterioration, distortion or compression to either of the system components.

NEW ERA *practical, cost effective, versatile & durable.*

System descriptions

Single component 90mm "Cradle" System S1 - S4

This extremely popular system is commonly used for an enormous variety of floor installations.

Typical installations being:-

Sports halls, Squash courts and Commercial offices and Domestic flooring under hardwood and composite surfaces.

As with all **NEW ERA** systems the cradles are polypropylene with a 10mm resilient foam - padded base and have an individual packing range of 20mm.

This system is supplied in 4 heights S1-S4, Construction range 74mm - 150mm.

Being of single components they are quick and simple to install and with no metal parts they are very safe to handle.

Double component "Height extender" System S5 - S9

The 2 component system has all the attributes and applications of the single "cradle" system and is specified where severe subfloor stepping is encountered.

The extender module simply increases the construction height by 74mm. Increased stability is offered by the 120mm wide base which tapers to house a 90mm wide "cradle".

No adhesives are required to join the two components, the cradle push fits into the base unit.

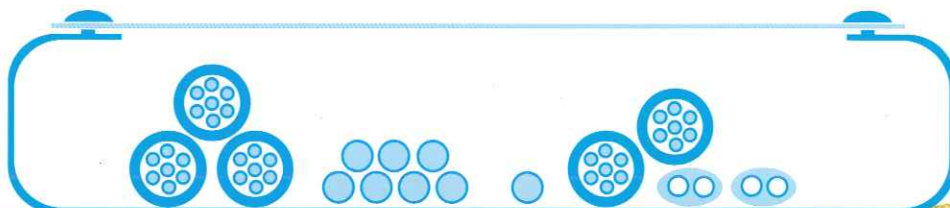
Construction range 133mm to 214mm.

The combined strength of these polypropylene components is enormous and they remain virtually indestructible through normal use.

Multi component "Towers" S10 - S24

The "Tower" system is an extension of the 2 component "height extender" module. The third component used form a tower is the 45mm "spacer". Spacers snap fit into any cradle* or other spacers increasing the overall component height by 45mm. The spacer(s) and attached cradle push fit into the 75mm

NEW ERA Theatres Hospitals Police stations **NEW ERA** Offices Houses Flats **NEW ERA**



Cable Trays

height extender base module thus forming a tower. **Note** * The S1 cradle is not used.

This system has many applications. Either as a 3 or 4 component module free standing levelling system, used with or independently to a single or double module system, or at increased heights within a subfloor well. For instance this system would allow for a hardwood floor to be installed within a "pedestal" computer floor without the cost of the metal floor to the "well" area.

**Quantity requirements -
Batten Centres & Cradle Centres -
Installation basics.**

The specifier's page in this brochure illustrates the required quantities of **NEW ERA** levelling elements and linear meterage of battens required per M2 for most common flooring installations.

There are too many system variations to list all installation requirements.

Basics

Batten 'centre' dimensions are normally totally subdivisible into the floorboard length.

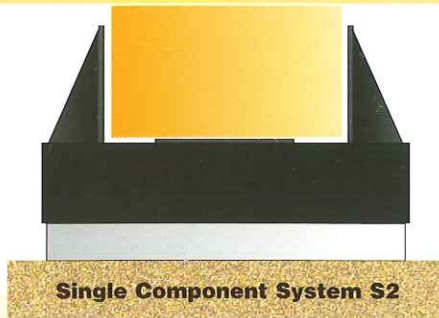
Battens are then 'set-out' at regular 'centres' to ensure that all board 'header' joints are fully supported by the battens.

Note: The main exception to this being with random length hardwood strip flooring commonly used for sports floors – For this type of floor system 305mm batten centres are used regardless of strip length.

Cradle 'centre' dimensions are dictated by the batten thickness.

Normally 'cradles' are positioned each 450mm along 36mm battens and each 600mm along 48mm battens. Both these 'centres' being totally sub divisible into the standard 1800mm batten length.

Note: In instances where battens of reduced thicknesses are specified i.e. 22mm thick. The cradle 'centres' should also be reduced to approximately 300mm. This is not a standard specification and your supplier should be consulted.

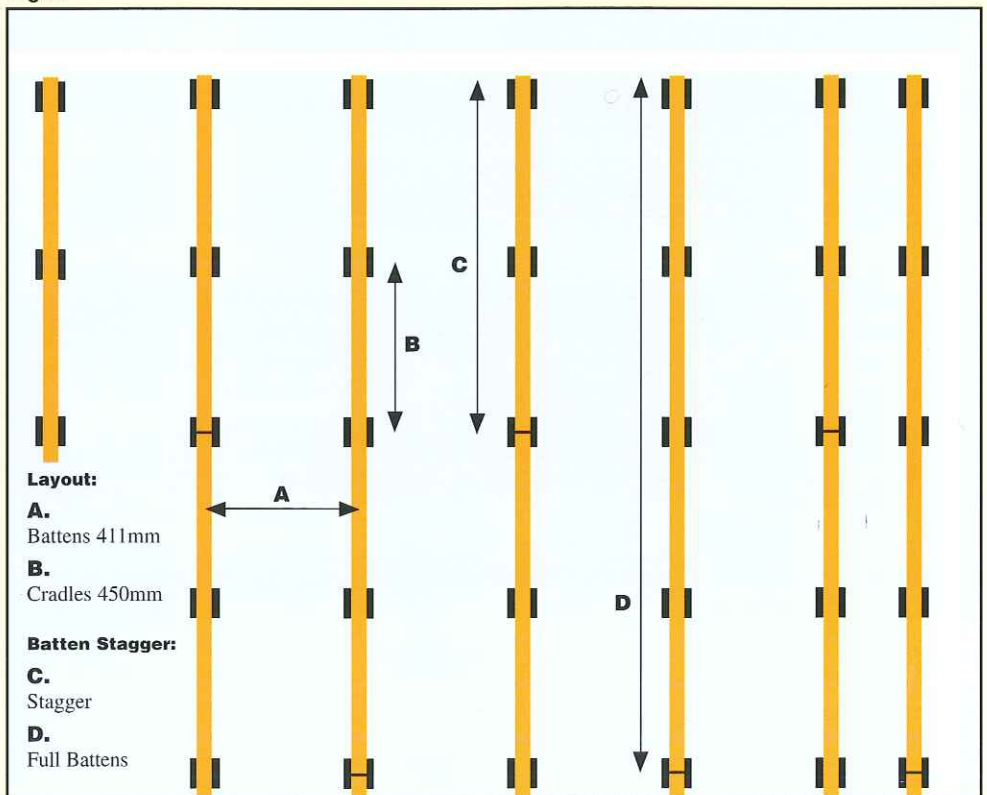


The system quantities per m2 shown on the specifiers page take into consideration perimeter and 'end' supports for batten runs.

see figure 1, which illustrates the necessary requirement of setting out battens in staggered lengths which enhances the strength of the system.

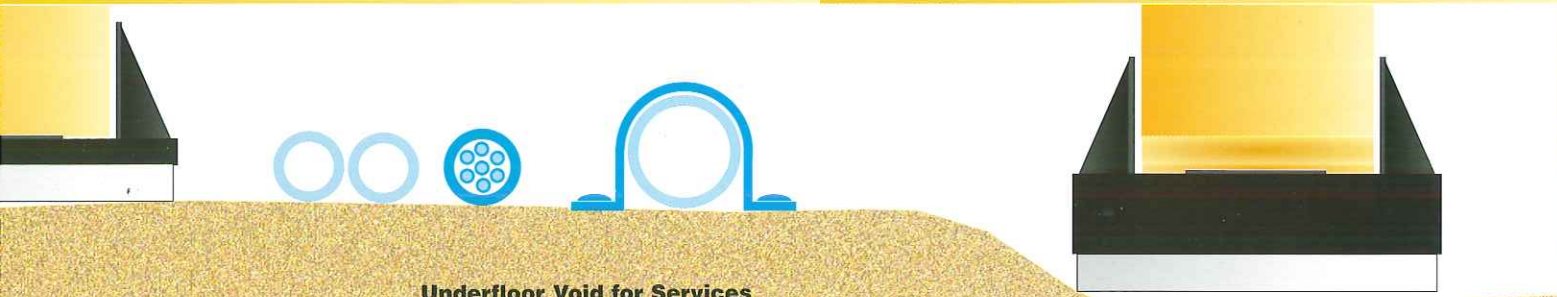


Fig.1.



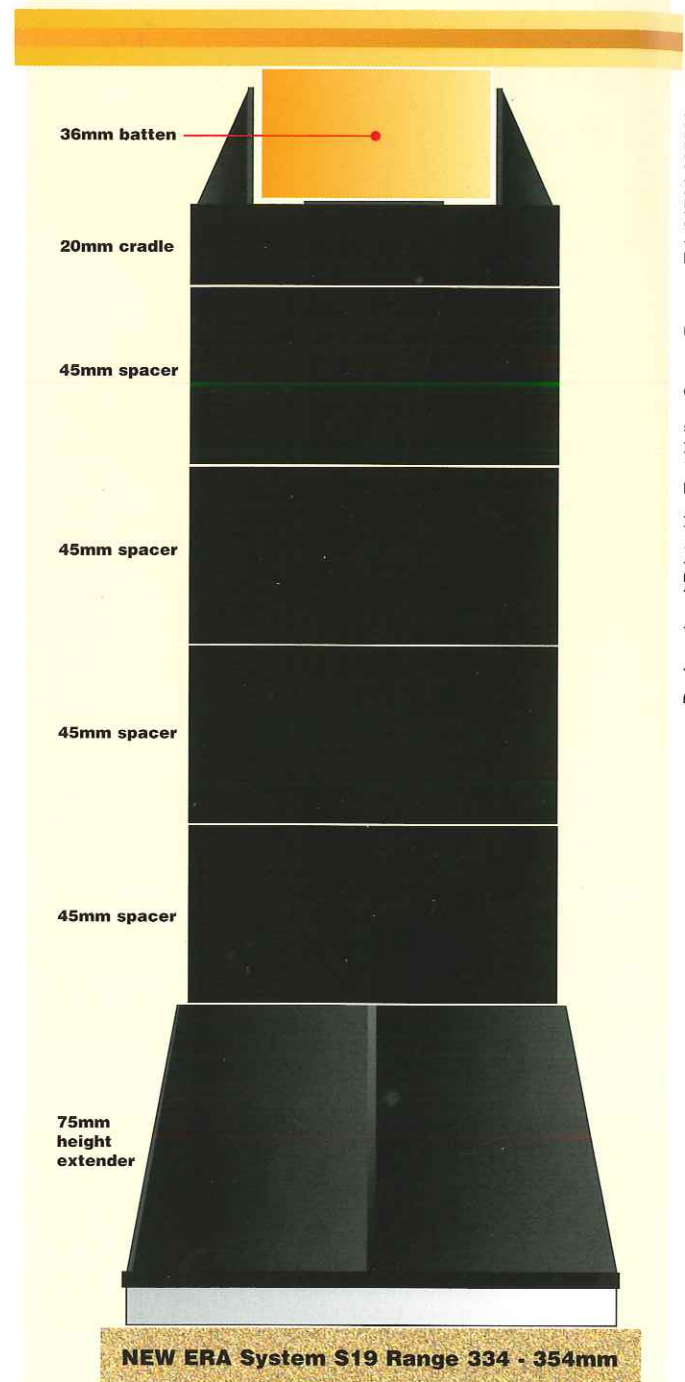
NEW ERA practical, cost effective, versatile and durable.

Museums Restaurants NEW ERA Barracks Schools Been there Done that NEW ERA



Underfloor Void for Services

Flooring Components	22mm Floor 36mm Batten	22mm Floor 48mm Batten
NEW ERA Systems	Construction Height & Packing Range	Construction Height & Packing Range
Single Unit		
System S1	74 - 94mm	86 - 106mm
System S2	88 - 108mm	100 - 120mm
System S3	103 - 123mm	115 - 135mm
System S4	118 - 138mm	130 - 150mm
Double Unit		
System S5	133 - 153mm	145 - 165mm
System S6	138 - 158mm	150 - 170mm
System S7	152 - 172mm	164 - 184mm
System S8	167 - 187mm	179 - 199mm
System S9	192 - 212mm	194 - 214mm
Multi - 3 Unit		
System S10	197 - 217mm	209 - 229mm
System S11	212 - 232mm	224 - 244mm
System S12	227 - 247mm	239 - 259mm
Multi - 4 Unit		
System S13	242 - 262mm	254 - 274mm
System S14	257 - 277mm	269 - 289mm
System S15	272 - 292mm	284 - 304mm
Multi - 5 Unit		
System S16	287 - 307mm	299 - 319mm
System S17	302 - 322mm	314 - 334mm
System S18	317 - 337mm	329 - 349mm
Multi - 6 Unit		
System S19	332 - 352mm	344 - 364mm
System S20	347 - 367mm	359 - 379mm
System S21	362 - 382mm	374 - 394mm
Multi - 7 Unit		
System S22	377 - 397mm	389 - 409mm
System S23	392 - 412mm	404 - 424mm
System S24	407 - 427mm	419 - 439mm



Floorboard length	Random Length				3700mm		2520mm		Domestic 2440mm	
	2440	305mm	305mm	406mm	406mm	411mm	411mm	420mm	420mm	488mm
Batten centres	305mm	305mm	406mm	406mm	411mm	411mm	420mm	420mm	488mm	488mm
Batten thickness	36mm	48mm	36mm	48mm	36mm	48mm	36mm	48mm	36mm	48mm
Cradle centres	450mm	600mm	450mm	600mm	450mm	600mm	450mm	600mm	450mm	600mm
Cradles req'd / m²	8.75no	6.5no	6.6no	4.9no	6.6no	5no	6.4no	4.8no	5.5no	4.1no
LM Batten req'd / m²	3.6Lm	3.6Lm	2.7Lm	2.7Lm	2.7Lm	2.7Lm	2.6Lm	2.6Lm	2.3Lm	2.3Lm

All NEW ERA systems have upto a 20mm Packing capability.

The system illustrated is the S1 with a 74mm - 94mm Construction Range (with 36mm batten/22mm floor board). Each System Range overlaps with the next i.e. System S2 overlaps System S1 by 6mm etc., see chart above.

Mix Systems in areas to overcome Level discrepancies greater than 20mm overall, according to Survey findings.

